

پمپ و کیوم والو



www.kalasanati.com



@kalasanati_com



+982188544230

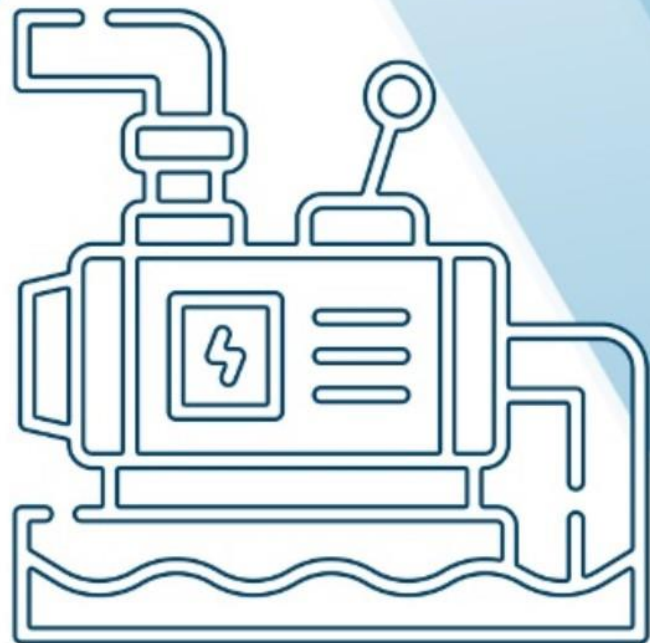

PUMP

www.kalasanati.com



از این که کالا صنعتی را انتخاب کرده اید از شما ممنونیم. گروه کالا صنعتی را میتوان بهترین شرکت برای مشاوره و خرید کالای صنعتی دانست. این شرکت با ترکیب صنعت و تکنولوژی توانسته بهترین خدمات مشاوره ای در زمینه خرید کالای صنعتی و به طور تخصصی پمپ آلات خانگی و صنعتی موجود در بازار را ارائه دهد. انواع پمپ آب خانگی، کفکش، لجن کش، موتور پمپ، شناور، پمپ وکیوم، بیستونی، دیافراگمی، پمپ دنده ای و بسیاری کالاهای مرتبط با این دسته بندی ها، در سایت کالا صنعتی قابل خرید بوده و سعی بر آن است که قیمت های درج شده کاملاً به روز باشد تا اینکه تصمیم گیری برای مشتریان و کارشناسان فنی شرکت ها آسان شود.

در راستای ارزشمندی مشاوره برای انتخاب پمپ، آماده کردن دیتاشیت و کاتالوگ های با کیفیت در دستور کار این شرکت قرار گرفته است. در ذیل دیتاشیت پمپ وکیوم آمده و این مشخصات مربوط به آخرین ویرایش شرکت سازنده می باشد.

- نکته: همواره سعی بر آن بوده که مشخصات و اطلاعات مربوط به کاتالوگ ها به صورت دقیق بازنویسی و نگارش شود. اما به صورت سهوی ممکن است اشکالات نگارشی در کاتالوگ وجود داشته باشد.





VEN Series

Vacuum Pump

Making Your Job More Enjoyable!

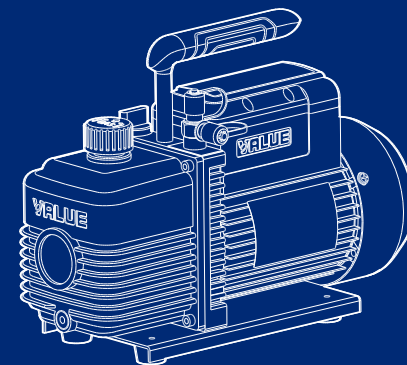

VALUE Mechanical & Electrical Products CO., LTD

Add: Jiulong Avenue, Western Industrial District, Wenling, Zhejiang, China

Tel: +86-576-86191959

Fax: +86-576-86191957

Email: value@worldvalue.cn

www.worldvalue.cn



VALUE • Quality Assurance

CONTENT

- I Safety precaution..... 1
- II Description..... 1
- III Pump components..... 3
 - 1. Operating..... 4
 - 1.1 Before operating..... 4
 - 1.2 To shut off the pump after use..... 5
 - 2. Maintenance..... 5
 - 2.1 Vacuum pump oil..... 5
 - 2.2 Oil change procedure..... 5
 - 3. Technical drawing..... 7
 - 4. Technical parameter..... 8
 - 5. Dual voltage and dual frequency series..... 10
 - 5.1 Outlook Structure..... 10
 - 5.2 Technical specification..... 10
 - 6. Trouble shooting..... 12
 - 7. Limited warranty statements..... 13

I Safety precaution

To prevent personal injury, please read the operating manual carefully

1. Wear goggles when working with refrigerants. Contact with refrigerants may cause injury.
2. Confirm all associated devices are grounded correctly before energizing circuit to avoid electrical shock hazards.
3. Normal operating temperature will cause certain portions of the pump to be hot to touch. Do not touch the pump housing or motor during operation.

II Description

VALUE vacuum pumps are widely used in the refrigeration service including CFC, HCFC, and HFC refrigerants, printing industry, vacuum packaging, gas analysis, thermo forming industry and so on. It can also be applicable as the pre-pump of various types of high vacuum equipment.

You will appreciate these key features:

1. High vacuum, high pump speed
Two stage rotary-vane design improves the ultimate vacuum and pump speed and reduces the evacuation time.
2. Integrated pump body design
Integrated pump body design ensures the reliability and easy maintenance.
3. Oil pump cycling system design
Built-in oil pump cycling design forced-lubricates the pump chamber and sliding bearing and ensures its lubrication and seal. Besides, big sight glass and low oil level design avoids running without oil and ensures reliable usage.

4. Anti-suckback design

Anti-suckback design prevents oil from returning to the system and keeping the purity of the system.

5. Lifetime Filtration

The intake filter can prevent foreign matter from entering into the pump chamber, and the exhaust fitting separates oil vapor from the exhaust flow.

6. Solid and comfortable handle

Special metal handle makes it easy to carry the pump and guarantee the pump's reliable use during operation. High quality rubber handle slipcover can always maintain its room temperature.

7. Good material

Aluminum oil housing, trestle and motor cover makes the pump light, metal base ensures the reliability of the pump.

8. Thermal protector

Thermal protector in the motor makes the pump run steadily and safety.

III Pump components

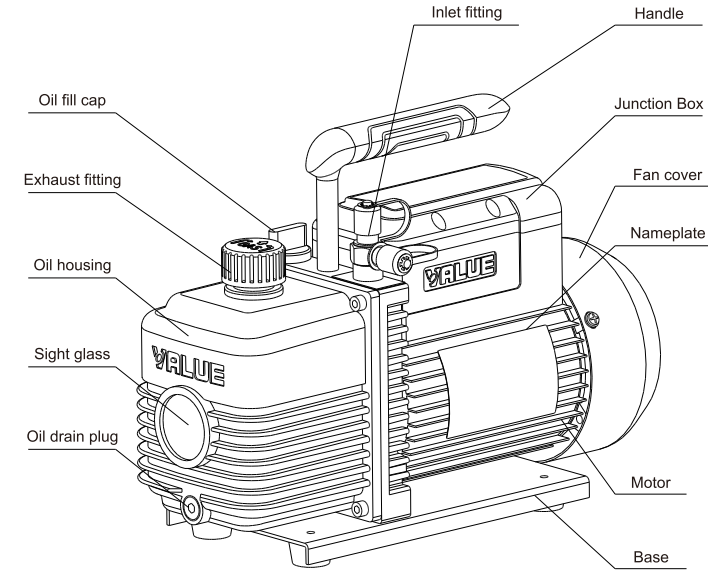

1. Operating

1.1 Before operating

All motors are designed for operating voltages plus or minus 10% of the normal rating. Single Voltage motors are supplied fully connected and ready to operate.

- Check the voltage and frequency at the outlet and ensure it matches the specifications on the pump motor nameplate. Ensure that the ON-OFF switch is in the OFF position before connecting the pump to a power source.
- Fill the oil reservoir with oil before activate the pump. Remove the Oil Fill Cap and add oil until oil level show in the middle between the Min and Max mark.



Refer to technical data in manual for the correct oil capacity of pump.

Attention: Filling speed can't be so fast in case of oil spillage.

- Place back the Oil Fill cap. Turn the motor switch to ON position. Place back the cap on the inlet fitting when the pump runs smoothly. This may takes 2 to 30 seconds depend on the ambient temperature. After the pump operates for approximately one minute, check the sight glass for proper oil level, which should always be visible in the middle between Max and Min mark. Refill oil if necessary.

Note: The oil level should always be visible in the middle between Max and Min mark when the pump is running. Insufficient oil filled will result in poor vacuum performance. Excessive of oil can result in overflowing of oil from the exhaust fitting.

- Oil mist will come out during operation. Special oil mist filter is needed if environment can't permit.

1.2 To shut off pump after use

To prolong pump life span and smooth start-up, these procedures to shut off pump should be followed.

- Turn off the manifold valve between the pump and the system.
- Remove the hose from the pump inlet.
- Cover the inlet port openings to prevent any contamination or foreign particles from entering the port.

2. Maintenance

2.1 Vacuum pump oil:

The condition and type of oil used in any high performance vacuum pump are extremely important in determining the ultimate attainable vacuum. It is recommended to use the High Performance Vacuum Pump Oil, which is specifically blended to maintain maximum viscosity at normal running temperatures and to improve cold weather start up.

2.2 Oil Change Procedure

- Ensure the pump is warmed up.
- Remove the Oil Drain cap. Drain off contaminated oil into a container and dispose it properly. Oil can be removed from the pump by opening the inlet and partially blocking the exhaust with a cloth while the pump is running. Do not operate the pump for more than 20 seconds using this method.
- When the drainage of oil completed, tilt the pump forward to remove the residual oil.
- Place back the Oil Drain Cap. Remove the Oil Fill Cap and fill the oil reservoir with new vacuum pump oil until oil level is seen in the middle between Max and Min mark.

- (e) Ensure that the inlet ports are covered before turn on the pump. Allow it to run for one minute to check the oil level. If the oil level is below the sight glass Min level, fill oil slowly (with the pump running) until the oil level show in the middle between Max and Min mark. Place back the Oil Fill cap, ensure the inlet is covered and the oil drain cap is closed tightly.
- (f) 1) If the oil is badly contaminated with sludge that forms during operation, you may need to remove the oil reservoir cover and wipe it.
- 2) The alternative method to deal with heavily contaminated oil is to force the oil from the pump reservoir. Leave the pump to run until it is warmed up. While the pump is still running, remove the oil drain cap and restrict the exhaust slightly. This will back-pressure the oil reservoir and purge the oil with contaminants. Turn off the pump when oil stops flowing.
- 3) Repeat this procedure as required until the contaminants is removed completely.
- 4) Replace the Oil Drain cap and refill the oil reservoir to the proper oil level with clean vacuum pump oil.

3. Technical Drawing

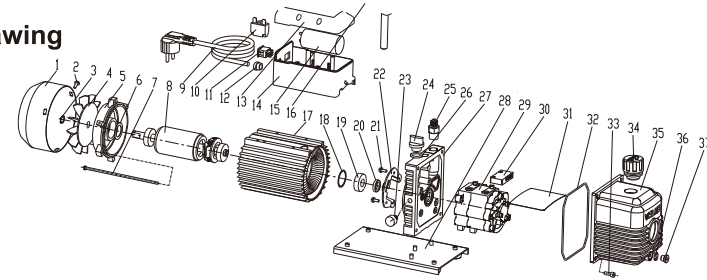

1	Fan cover	14	Junction box	27	Trestle
2	Cross screw	15	Capacitor	28	Base
3	Elastic collar	16	Handle	29	Pump body
4	Fan	17	Motor stator assy.	30	Anti-oil cover
5	Motor cover	18	Gasket	31	Anti-oil plate
6	Gasket	19	Bearing	32	O ring
7	Cross screw	20	Seal	33	Screw
8	Motor rotor	21	Cross screw	34	Exhausting and oil inlet fitting
9	Power supply cord	22	Centrifugal switch base	35	Oil housing assy.
10	Thermal protector	23	Gas ballast (2 stage only)	36	O ring
11	Power switch	24	Oil fill cap	37	Oil drain plug
12	Insulating bushing	25	Inlet fitting		
13	Junction box cover	26	O ring		

4. Technical paramete

Single Stage Vacuum Pump											
Model		VE115N		VE125N		VE135N		VE160N		VE180N	
Frequency		50Hz	60Hz	50Hz	60Hz	50Hz	60Hz	50Hz	60Hz	50Hz	60Hz
Flow Rate	CFM	1.8	2.0	2.5	3.0	3.5	4.0	6.0	7.0	8.0	9.0
	L/min	51	57	70	84	100	113	170	198	226	254
Ultimate Vacuum	Partial pressure	2Pa		2Pa		2Pa		2Pa		2Pa	
	Total pressure	150 micron		150 micron		150 micron		150 micron		150 micron	
Motor (HP)		1/4		1/4		1/3		1/2		3/4	
Intake Fitting		1/4 " Flare		1/4 " Flare		1/4" &3/8" Flare		1/4" &3/8" Flare		1/4" &3/8" Flare	
Oil Capacity (ml)		250		250		250		415		660	
Dimensions (mm)		290×124×224		290×124×224		318×124×234		337×138×244		395×145×257	
Net Weight (kg)		6.6		7.1		8.0		10.0		14.7	

Dual Stage Vacuum Pump															
Model		VE215N		VE225N		VE235N		VE245N		VE260N		VE280N		VE2100N	
Frequency		50Hz	60Hz	50Hz	60Hz	50Hz	60Hz	50Hz	60Hz	50Hz	60Hz	50Hz	60Hz	50Hz	60Hz
Flow Rate	CFM	1.5	1.8	2.5	3.0	3.5	4.0	4.5	5.0	6.0	7.0	8.0	9.0	10.0	12.0
	L/min	42	50	70	84	100	113	128	142	170	198	226	254	283	340
Ultimate Vacuum	Partial pressure	2×10 ⁻¹ Pa		2×10 ⁻¹ Pa		2×10 ⁻¹ Pa		2×10 ⁻¹ Pa		2×10 ⁻¹ Pa		2×10 ⁻¹ Pa		2×10 ⁻¹ Pa	
	Total pressure	15 micron		15 micron		15 micron		15 micron		15 micron		15 micron		15 micron	
Motor (HP)		1/4		1/3		1/3		1/2		3/4		1		1	
Intake Fitting		1/4 " Flare		1/4 " Flare		1/4" &3/8" Flare		1/4" &3/8" Flare		1/4" &3/8" Flare		1/4" &3/8" Flare		1/4" &3/8" Flare	
Oil Capacity (ml)		200		200		325		325		460		500		700	
Dimensions (mm)		308×124×230		318×124×234		337×138×244		337×138×244		395×145×257		395×145×257		395×145×257	
Net Weight (kg)		7.5		8.6		10.5		10.5		15.9		16.3		16.7	

5. Dual Voltage & Dual Frequency Series

5.1 Outlook Structure

Refer to rightside outlook drawing for better understanding of “Dual Voltage & Dual Frequency” Series.

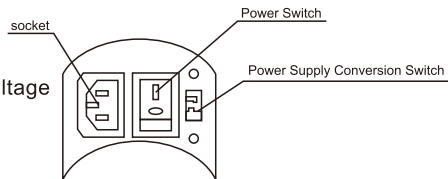

5.2 Technical specification

Dual Voltage Vacuum Pump

Model		VE215ND		VE225ND		VE235ND		VE245ND		VE260ND		VE280ND		VE2100ND	
Frequency		50Hz	60Hz	50Hz	60Hz	50Hz	60Hz	50Hz	60Hz	50Hz	60Hz	50Hz	60Hz	50Hz	60Hz
Flow Rate	CFM	1.5	1.8	2.5	3.0	3.5	4.0	4.5	5.0	6.0	7.0	8.0	9.0	10.0	12.0
	L/min	42	50	70	84	100	113	128	142	170	198	226	254	283	340
Ultimate Vacuum	Partial pressure	2×10 ⁻¹ Pa		2×10 ⁻¹ Pa		2×10 ⁻¹ Pa		2×10 ⁻¹ Pa		2×10 ⁻¹ Pa		2×10 ⁻¹ Pa		2×10 ⁻¹ Pa	
	Total pressure	15 micron		15 micron		15 micron		15 micron		15 micron		15 micron		15 micron	
Motor (HP)		1/4		1/3		1/3		1/2		3/4		1		1	
Intake Fitting		1/4 " Flare		1/4 " Flare		1/4" & 3/8" Flare		1/4" & 3/8" Flare		1/4" & 3/8" Flare		1/4" & 3/8" Flare		1/4" & 3/8" Flare	
Oil Capacity (ml)		200		200		325		325		460		500		700	
Dimensions (mm)		318×124×234		318×124×234		337×138×244		337×138×244		395×145×257		395×145×257		395×145×257	
Net Weight (kg)		8.4		8.6		10.5		10.5		15.9		16.3		16.7	

Note: 1.This product operates in ambient temperature: 5°C~40°C

2.Power supply of the products are 110-120V/60Hz and 220-240V/50-60Hz

Check power supply parameter before using the vacuum pump and ensure the “Power Supply Conversion Switch” is set at the right place: 110V or 220V.

Warning : If the ambient temperature is too hot or the voltage is too high, the product may stop functioning. It is recommended not to switch off the power supply immediately. If the product re-startup automatically after 3 minutes, it is recommended to cool the product by lowering the ambient temperature or power supply voltage to prolong the life span of the vacuum pump.

6. Trouble shooting

Fault	Possible cause	Remedy	Remark
Failure to attain a good vacuum	<ol style="list-style-type: none"> 1. The spare intake port cap loosen 2. O-Ring inside the spare intake port cap damage. 3. Insufficient oil 4. Pump oil emulsification or dirty 5. Oil inlet channel is clogged or insufficient oil 6. Pumping system leak 7. Not suitable pump 8. Pump spare parts are worn out after long use 	<ol style="list-style-type: none"> 1. Fasten the intake port cap 2. Change the O ring 3. Add oil 4. change oil 5. Clean the oil inlet channel, clean the filter screen 6. Check the pumping system, no leakage 7. Chose the right pump 8. Repair the pump or replace the pump if necessary. 	
Oil leakage	<ol style="list-style-type: none"> 1. Oil seal damage 2. Oil housing assy connections loosen or damage. 	<ol style="list-style-type: none"> 1. Change oil seal 2. Fasten the screw and change the O ring in the oil housing assy. 	
Oil injection	<ol style="list-style-type: none"> 1. Excessive oil in the pump 2. Continuous operation under high pressure in the inlet port 	<ol style="list-style-type: none"> 1. Drain oil 2. Chose the right pump 	
Failure to start	<ol style="list-style-type: none"> 1. Oil temperature is too low 2. Malfunction of motor or power supply 3. Foreign matters entered into the pump chamber 4. The voltage is too low 5. The power supply extended line is too long 	<ol style="list-style-type: none"> 1. Start the pump repeatedly while keep the pump oil free or heat the pump oil 2. Check and repair 3. Check and clean the pump 4. Check the operating voltage 5. Shorten the power supply extended line. 	

Remark: If these procedures do not correct the problem, contact with your nearest VALUE distributor or send your pump to our service centre, we will do our best to help you.

7. Limited warranty statement

Warranty period is one year from the purchase date due to the quality of the products itself.

The following restrictions apply:

1. The warranty applies to the product in normal usage situation only, as described in the operating manual. All warranty service claims must be made within the specified warranty period. Proof-of-purchase date must be supplied to the manufacturer.
2. Warranty service claims are subject to authorized inspection for product defects.
3. Warranty service applies to the product without un-authorized repairing or dis-assembling.

Remark: The manufacturer shall not be responsible for any additional costs associated with a product failure, including loss of work time, loss of refrigerant, cross-contamination of refrigerant, and unauthorized shipping or labor charges.